

Data sheets

For standard refrigerants > Standard series

Technical data:		
Cylinders	#	8
Displacement @ 50 Hz	m ³ /h [50Hz]	227.8
Displacement @ 60 Hz	m ³ /h [60Hz]	273.3
Motor version[1]		1
Nominal Motor power	HP	75
Nominal Motor power	kW	55.5
Motor voltage at 50 Hz[2]	V/ph/Hz	380-420V/3/50Hz PWS
Motor voltage at 60 Hz[2]	V/ph/Hz	440-480V/3/60Hz PWS
PWS partition		50-50
CC Head capacity control steps	%	100-75-50
MRA, max operating current at 400V/50Hz and 460V/60Hz	A	128.4
LRA, max starting current at 400V/50Hz and 460V/60Hz, PWS motor	A	417
LRA, max starting current at 400V/50Hz and 460V/60Hz, PWS motor-DOL connection	A	584
Frequency min	Hz	30
Frequency max[3]	Hz	70
Electric terminal box class protection		IP65
Maximum pressure HP	bar	30
Maximum pressure LP	bar	20.5
Oil type[4]		POE68
Oil charge (3/4 of sight glass)	l	7.7
Lubrication type		Oil pump
Suction valve (SV)	inch	3½
Discharge valve (DV)	inch	2½
Net weight	kg	328
Max Length	mm	864
Max Width	mm	519
Max Height	mm	588
Rubber mounts diameter	mm	50
Rubber mounts height	mm	40
Rubber mounts shore	sh	73
Sound power level (-10/45, R404A)[5]	dB(A)	89.4
Sound pressure level @ 1m (-10/45, R404A)[5]	dB(A)	81.4
Compressor body material		Ghisa GJL250
RSH Head capacity control steps	%	100-87-75-63-50
Motor protection		PTC
Control, diagnostics and protection device		INT69® TML Diagnose
Oil level sight glass	#	2

- [1] Motor version: 1 = high and mid temp. all refrigerants; 2 = low and mid temp. all refrigerants; 3 = ECOinside, low temp. R134a, R1234ze, R1234yf only
- [2] Other motor voltage available on request
- [3] Maximum frequency depends on the working conditions: use the FSS.3 (Frascold selection software)
- [4] For alternative lubricants refer to bulletin FTEC022
- [5] Sound pressure in free field, hemispherical model at 1 meter distance, 50Hz; PWL and SPL in different conditions are available on

Data sheets

For standard refrigerants > Standard series

Accessories:	
Oil heater (230V-150W)	T00CH9-RIC
CC capacity control head 230V AC	T00SK220200
RSH capacity control head 230V AC	T00SK220400
US unloader start head 230V AC	T00SK250200
Head cooling fan - 230-400V/3/50-60Hz	SZ-FM4
Water cooled head	T00SK50000
Electronic oil level regulator - INT280 Diagnose 230V AC	T00EC1900
Electronic oil level switch (230V)	T00WK252
Kit adapters for oil equalization line - 1" ROT 5/8" ODS	T00SK170200
Kit adapters for oil equalization line - 1"1/4 ROT 1"1/8 ODS	T00SK170300
USB adapter cable	T00EC57
Connection cable Modbus Gateway - INT69	T00EC65
DP Modbus Gateway	T00EC59

Data sheets

For standard refrigerants > Standard series

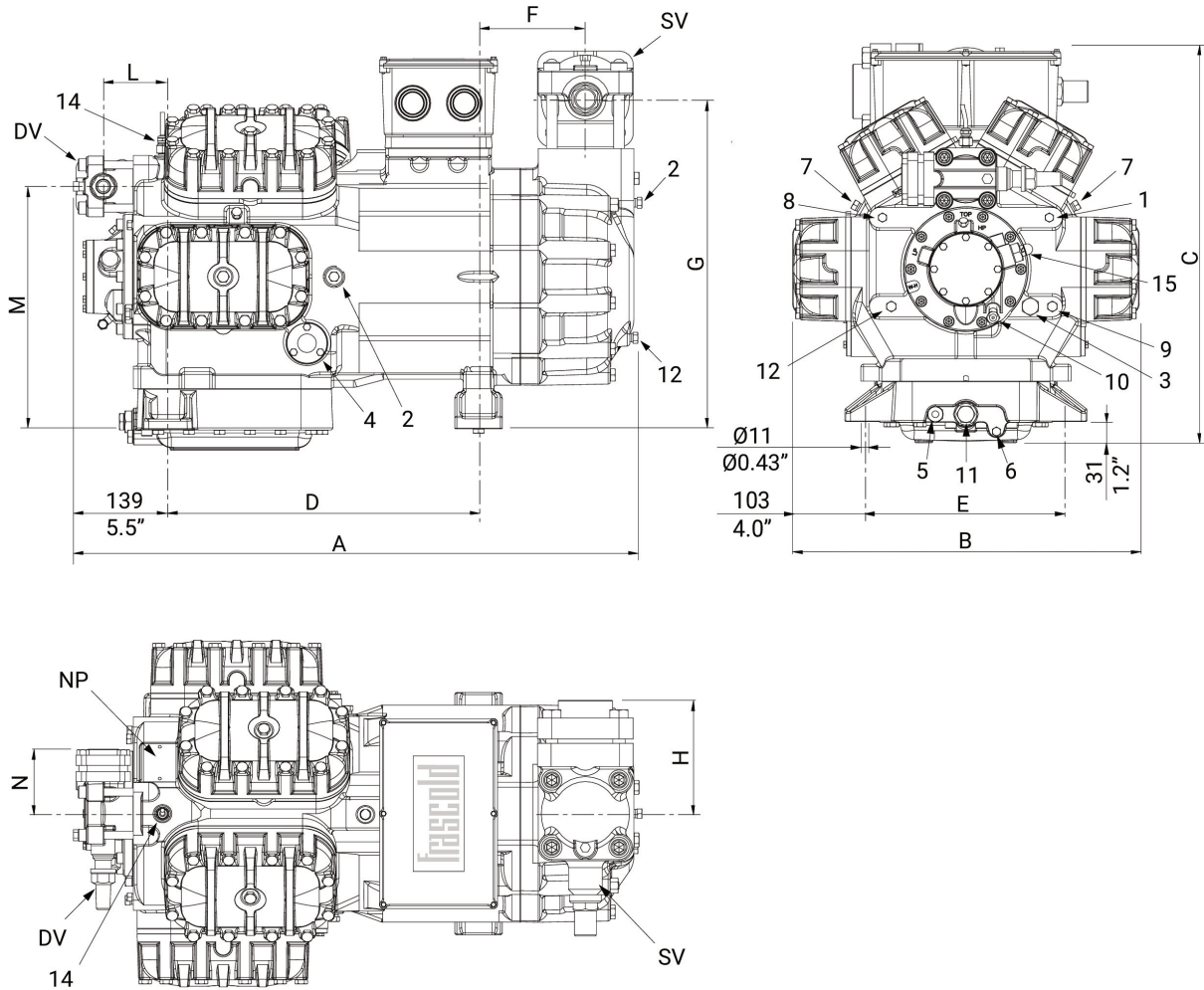

Dimensional drawing:

SV Suction valve (SV)	mm	79.4
DV Discharge valve (DV)	mm	54
SV Suction valve (SV)	inch	3 $\frac{1}{8}$
DV Discharge valve (DV)	inch	2 $\frac{1}{8}$
A Length (A)	mm	864
B Width (B)	mm	519
C Height (C)	mm	588
D Base mounting (D)	mm	458
E Base mounting (E)	mm	305
F Suction valve (F)	mm	190
G Suction valve (G)	mm	486
H Suction valve (H)	mm	160
L Discharge valve (L)	mm	95
M Discharge valve (M)	mm	358
N Discharge valve (N)	mm	162
1 High pressure plug (1)		1/8" NPT

2 Low pressure plug (2)		1/4" NPT
3 Oil charge plug (3)		3/8" GAS
4 Oil level sight glass (4)		-
5 Crankcase heater (5)		-
6 Oil drain plug (6)		1/4" GAS
7 Liquid injection valve plug (7)		1/4" NPT
8 Liquid injection sensor plug (8)		1/8" NPT
9 Oil pressure switch connection (LP)		1/4" NPT
10 Oil pressure switch connection (HP)		1/4" SAE
11 Oil filter (11)		3/8" GAS
12 Oil return plug (12)		1/4" NPT
14 Max. discharge temperature sensor (14)		-
15 Electronic oil pressure switch connection		-
NP Name Plate (NP)		-